

# A6HP

High Pressure Piston Pumps  
600-700 BAR



**A6PH Pumps have the following advantages ;**

- 600 bar Cont. Work. Pressure,
- 700 bar Peak Pressure,
- From 02cc to 45cc, (1500 rpm)
- Reduced Noise Level,
- Special Cast Iron with Raw Materials
- For Industrial Area,
- Economical Conception,
- High Rotating Speeds,
- High Output Pressure.

# High Pressure Piston Pumps

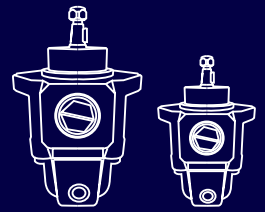

		02	04	06	12	15	22	35	45
<b>Displacement</b>	<b>cc</b>	1,56	2,70	4,40	7,80	10,50	14,73	23,70	30,40
<b>Theoretical oil flow l/min at pump speed</b>	<b>1000 rpm</b>	1,56	2,70	4,40	7,80	10,50	14,73	23,70	30,40
	<b>1500 rpm</b>	2,34	4,05	6,60	11,70	15,75	22,09	35,55	45,60
<b>Maximum Pump Speed</b>									
- Continuous	<b>rpm</b>	3000	3000	3000	2800	2800	2800	2500	2400
- Limited	<b>rpm</b>	3500	3500	3500	3000	3000	3000	2800	2700
<b>Max. Continuous Pressure</b>	<b>bar</b>	600	600	600	450	400	400	400	400
<b>Max. Peak Pressure</b>	<b>bar</b>	700	700	700	500	500	500	500	500
<b>Weight</b>									
- Without inlet fitting	<b>kg</b>	5,50	5,50	5,50	8,00	8,00	8,00	12,00	12,00
- With inlet fitting	<b>kg</b>	5,60	5,60	5,60	8,15	8,15	8,15	12,25	12,25
<b>Fluid</b>	Mineral Based Hydraulic Oils								
<b>Inlet</b>		G 1"	G 1"	G 1"	G1 1/4"	G1 1/4"	G1 1/4"	47,8mm	47,8mm
<b>Outlet</b>		G 3/8"	G 3/8"	G 3/8"	G 1/2"	G 1/2"	G 1/2"	26,4mm	26,4mm

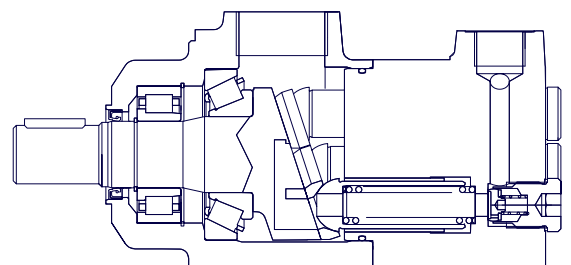
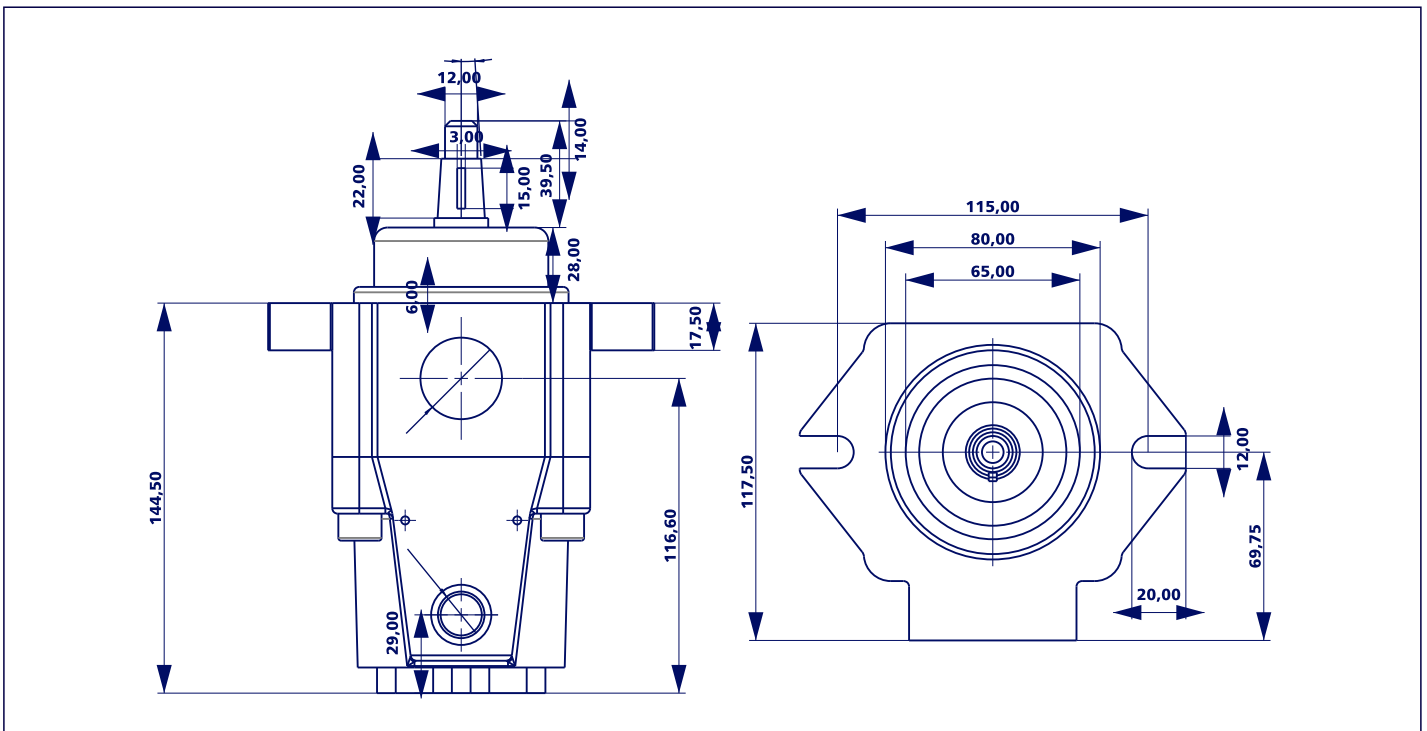

# Ordering Code of A6HP Pumps

Pump Code

Displacement ( cm<sup>3</sup> )

**A6HP**

**45**

**02**

**04**

**06**

**12**

**15**

**22**

**35**

**45**

**A6HP** High Pressure Piston Pump, Fixed Displacement, 2 BOLT Mounting Flange

## Formulas

<b>Pump Output Flow</b>	GPM	$GPM = (\text{Speed (rpm)} \times \text{disp. (cu. in.)}) / 231$	$GPM = (n \times d) / 231$
<b>Pump Input Horsepower</b>	HP	$HP = GPM \times \text{Pressure (psi)} / 1714 \times \text{Efficiency}$	$HP = (Q \times P) / 1714 \times E$
<b>Pump Efficiency</b>	E	Overall Efficiency = Output HP / Input HP	$E_{\text{Overall}} = \text{HP}_{\text{Out}} / \text{HP}_{\text{In}} \times 100$
		Overall Efficiency = Volumetric Eff. $\times$ Mechanical Eff.	$E_{\text{Overall}} = \text{EffVol.} \times \text{EffMech.}$
<b>Pump Volumetric Efficiency</b>	E	Volumetric Efficiency = Actual Flow Rate Output (GPM) / Theoretical Flow Rate Output (GPM) $\times$ 100	$\text{EffVol.} = Q_{\text{Act.}} / Q_{\text{Theo.}} \times 100$
<b>Pump Mechanical Efficiency</b>	E	Mechanical Efficiency = Theoretical Torque to Drive / Actual Torque to Drive $\times$ 100	$\text{EffMech} = T_{\text{Theo.}} / T_{\text{Act.}} \times 100$
<b>Pump Displacement</b>	CIPR	$\text{Displcmnt (In.}^3 \text{ / rev.)} = \text{Flow Rate (GPM)} \times 231 / \text{Pump RPM}$	$\text{CIPR} = GPM \times 231 / \text{RPM}$
<b>Pump Torque</b>	T	Torque = Horsepower $\times$ 63025 / RPM	$T = 63025 \times \text{HP} / \text{RPM}$
		Torque = Pressure (PSIG) $\times$ Pump Displacement (CIPR) / $2\pi$	$T = P \times \text{CIPR} / 6.28$

**Horsepower for driving a pump** : For every 1 hp of drive, the equivalent of 1 gpm @ 1500 psi can be produced.

**Horsepower for idling a pump** : To idle a pump when it is unloaded will require about 5% of it's full rated power

**Wattage for heating hydraulic oil** : Each watt will raise the temperature of 1 gallon of oil by 1° F. per hour.

**Flow velocity in hydraulic lines** : Pump suction lines 2 to 4 feet per second, pressure lines up to 500 psi - 10 to 15 ft./sec., pressure lines 500 to 3000 psi - 15 to 20 ft./sec.; all oil lines in air-over-oil systems; 4 ft./sec.

# Technical Data

		02	04	06	12	15	22	35	45	
<b>Displacement</b>	<b>cc</b>	1,56	2,70	4,40	7,80	10,50	14,73	23,70	30,40	
<b>Theoretical oil flow l/min at pump speed</b>	<b>1000 rpm</b>	1,56	2,70	4,40	7,80	10,50	14,73	23,70	30,40	
	<b>1500 rpm</b>	2,34	4,05	6,60	11,70	15,75	22,09	35,55	45,60	
<b>Maximum Pump Speed</b>	- Continuous	<b>rpm</b>	3000	3000	3000	2800	2800	2800	2500	2400
	- Limited	<b>rpm</b>	3500	3500	3500	3000	3000	3000	2800	2700
	<b>bar</b>	600	600	600	450	400	400	400	400	
<b>Max. Peak Pressure</b>	<b>bar</b>	700	700	700	500	500	500	500	500	
<b>Weight</b>	- Without inlet fitting	<b>kg</b>	5,50	5,50	5,50	8,00	8,00	8,00	12,00	12,00
	- With inlet fitting	<b>kg</b>	5,60	5,60	5,60	8,15	8,15	8,15	12,25	12,25
<b>Fluid</b>		Mineral Based Hydraulic Oils								
<b>Inlet</b>		G 1"	G 1"	G 1"	G1 1/4"	G1 1/4"	G1 1/4"	47,8mm	47,8mm	
<b>Outlet</b>		G 3/8"	G 3/8"	G 3/8"	G 1/2"	G 1/2"	G 1/2"	26,4mm	26,4mm	

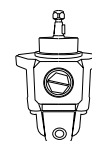

**CW**

Rotation :  
Fixed-Clock Wise

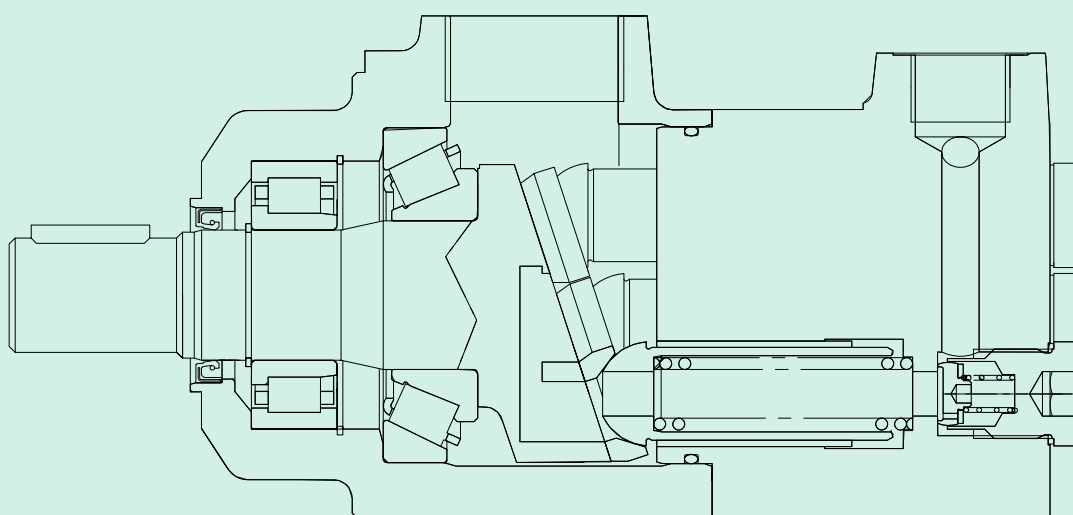

# Performance

Efficiency Curves ( 1000 rpm )

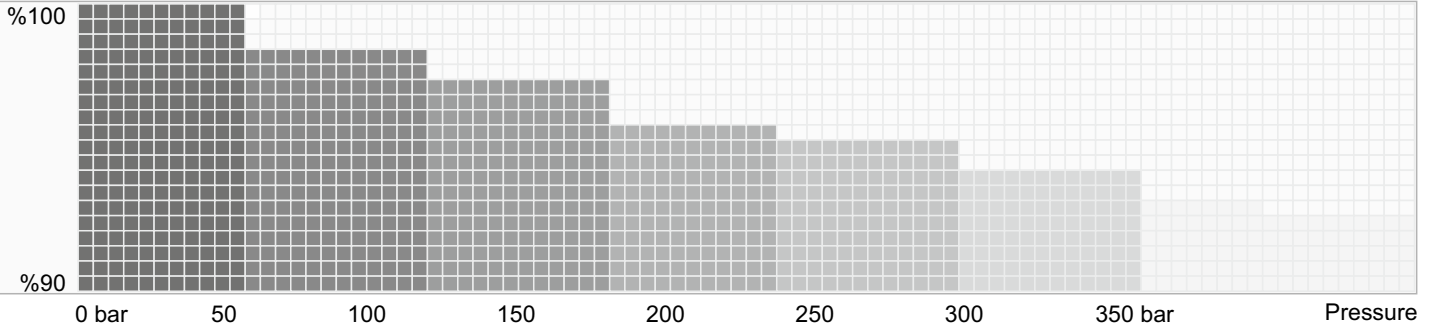

Flow

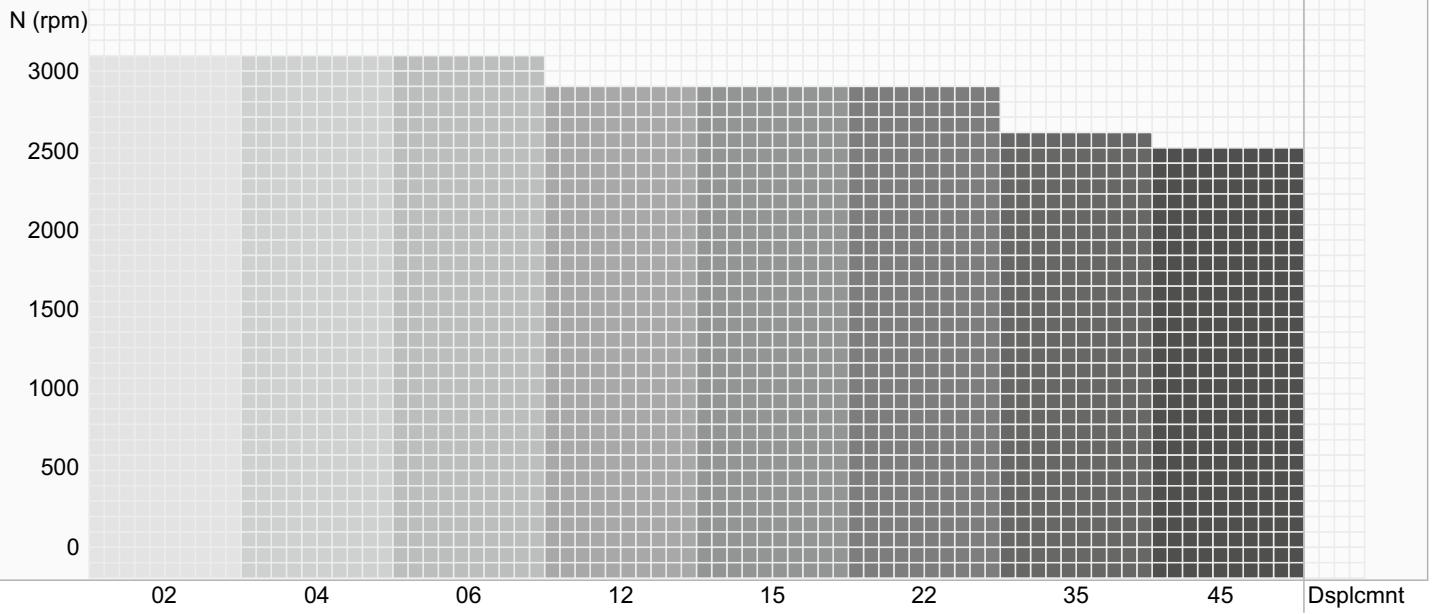

# A6HP 02

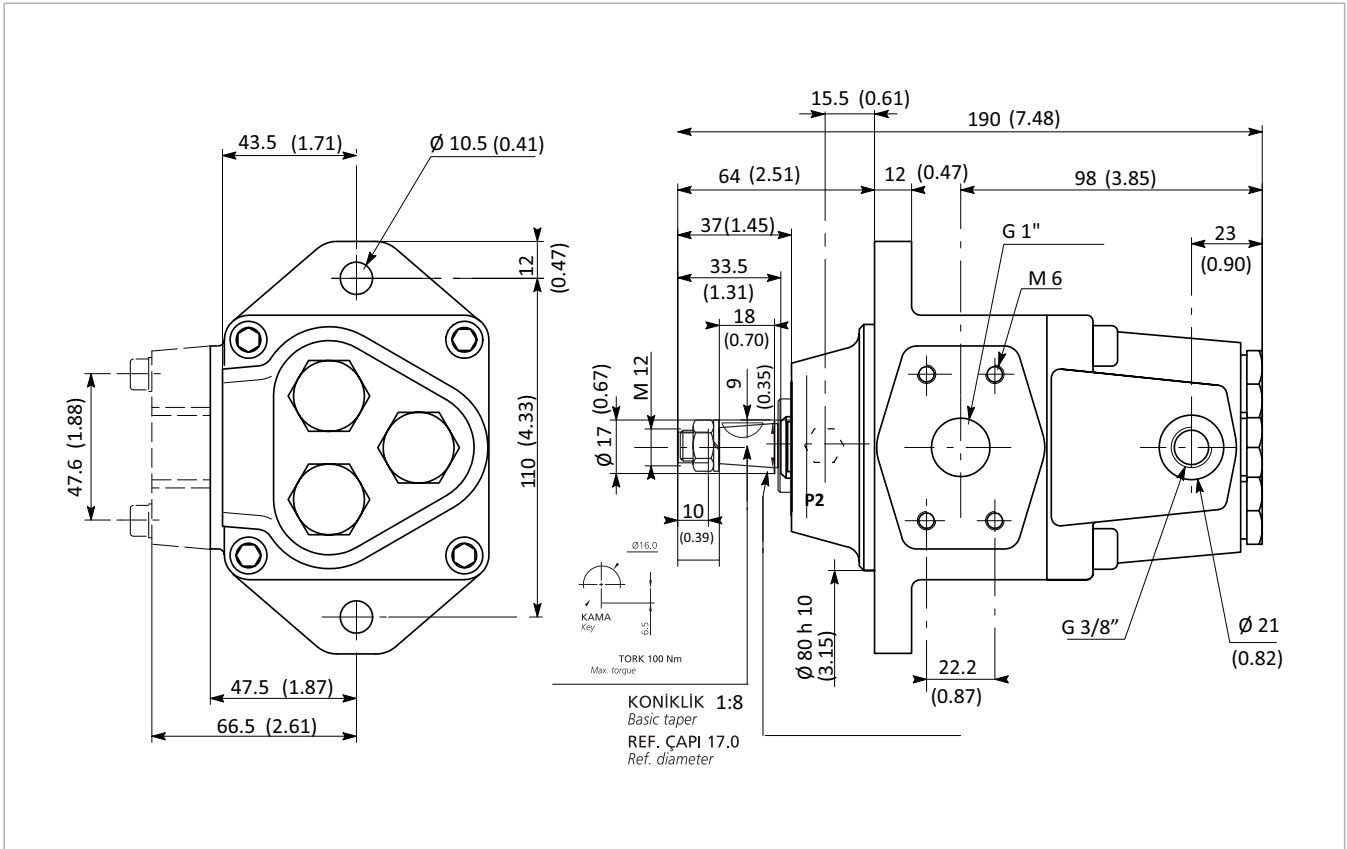

<b>x 1000 rpm</b>	1,56 cc
<b>x 1500 rpm</b>	2,34 cc
<b>Max. Continuous Pump Speed</b>	3000 rpm
<b>Max. Limited Pump Speed</b>	3500 rpm
<b>Max. Continuous Pressure</b>	600 bar
<b>Max. Intermit. Peak Pressure</b>	700 bar
<b>Weight without inlet fitting</b>	5,50 kg
<b>Weight with inlet fitting</b>	5,60 kg
<b>Fluid</b>	Min.B.Hyd.Oil
<b>Inlet</b>	G 1"
<b>Outlet</b>	G 3/8"

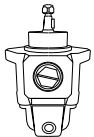

## CW

Rotation :  
Fixed-Clock Wise

# A6HP 04

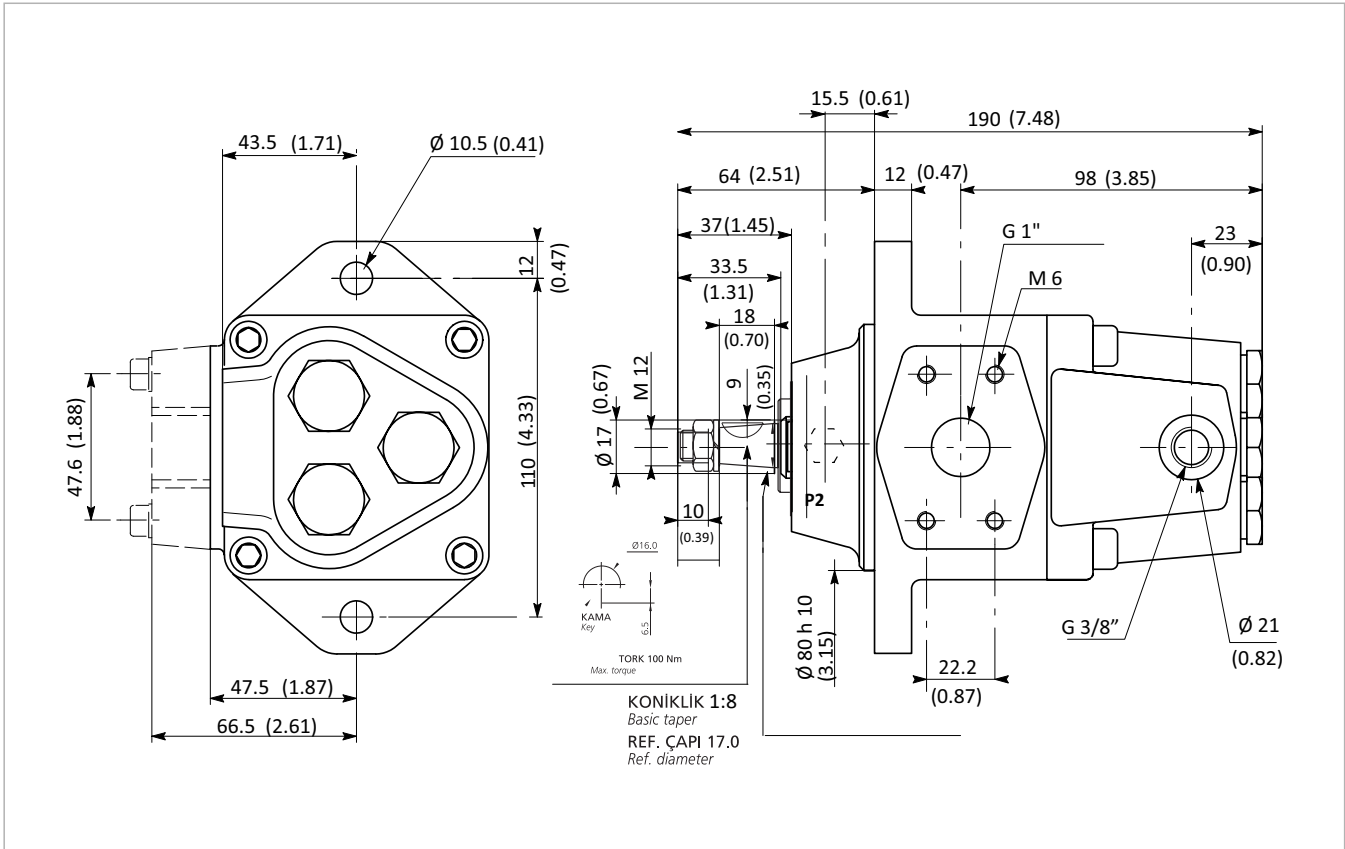

<b>x 1000 rpm</b>	2,70 cc
<b>x 1500 rpm</b>	4,05 cc
<b>Max. Continuous Pump Speed</b>	3000 rpm
<b>Max. Limited Pump Speed</b>	3500 rpm
<b>Max. Continuous Pressure</b>	600 bar
<b>Max. Intermit. Peak Pressure</b>	700 bar
<b>Weight without inlet fitting</b>	5,50 kg
<b>Weight with inlet fitting</b>	5,60 kg
<b>Fluid</b>	Min.B.Hyd.Oil
<b>Inlet</b>	G 1"
<b>Outlet</b>	G 3/8"

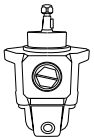

## CW

Rotation :  
Fixed-Clock Wise

# A6HP 06

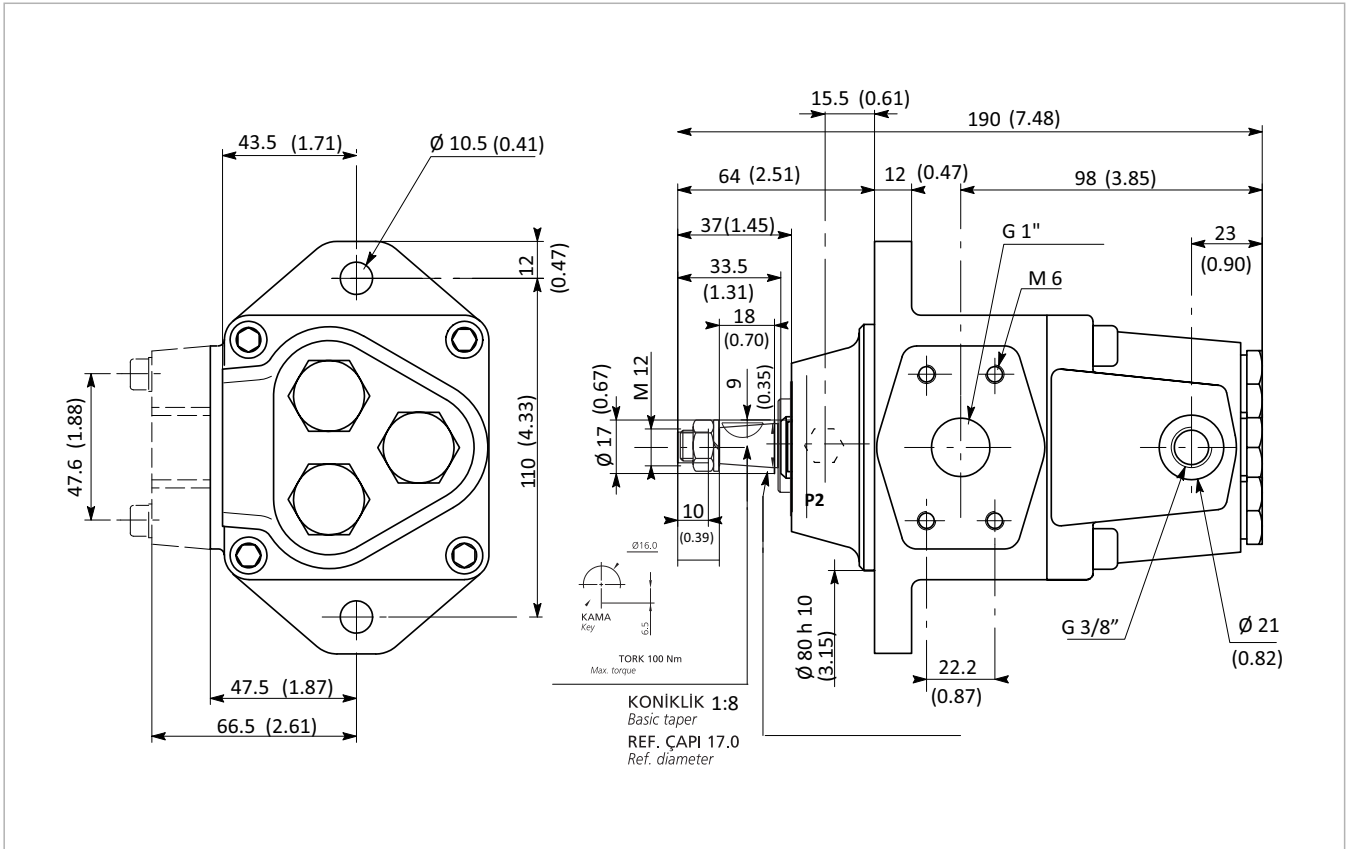

<b>x 1000 rpm</b>	4,40 cc
<b>x 1500 rpm</b>	6,60 cc
<b>Max. Continuous Pump Speed</b>	3000 rpm
<b>Max. Limited Pump Speed</b>	3500 rpm
<b>Max. Continuous Pressure</b>	600 bar
<b>Max. Intermit. Peak Pressure</b>	700 bar
<b>Weight without inlet fitting</b>	5,50 kg
<b>Weight with inlet fitting</b>	5,60 kg
<b>Fluid</b>	Min.B.Hyd.Oil
<b>Inlet</b>	G 1"
<b>Outlet</b>	G 3/8"

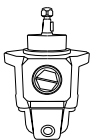

## CW

Rotation :  
Fixed-Clock Wise

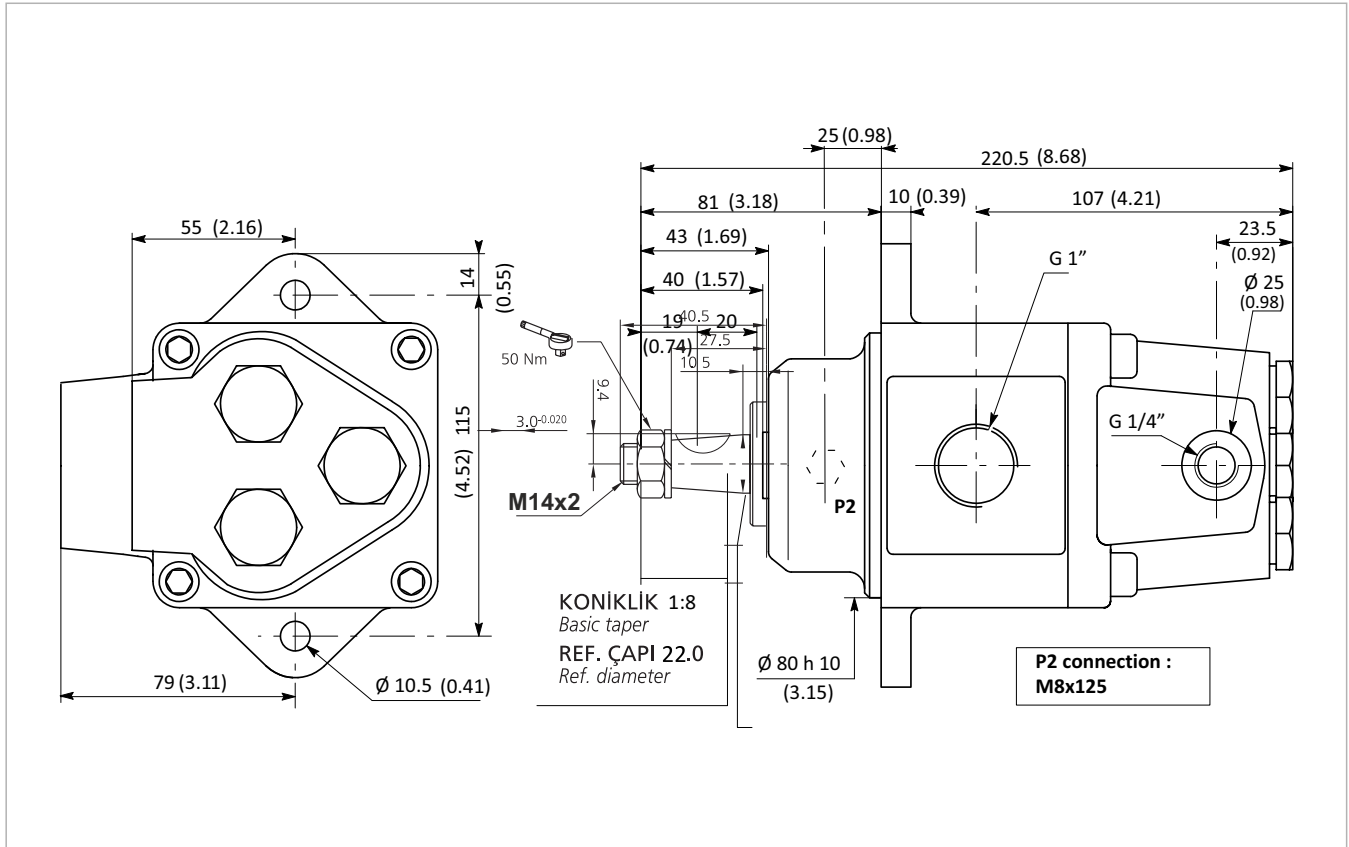

**A6HP 12**

<b>x 1000 rpm</b>	7,80 cc
<b>x 1500 rpm</b>	11,70 cc
<b>Max. Continuous Pump Speed</b>	2800 rpm
<b>Max. Limited Pump Speed</b>	3000 rpm
<b>Max. Continuous Pressure</b>	450 bar
<b>Max. Intermit. Peak Pressure</b>	500 bar
<b>Weight without inlet fitting</b>	8,00 kg
<b>Weight with inlet fitting</b>	8,15 kg
<b>Fluid</b>	Min.B.Hyd.Oil
<b>Inlet</b>	G1 1/4"
<b>Outlet</b>	G 1/2"

**CW**Rotation :  
Fixed-Clock Wise

# A6HP15

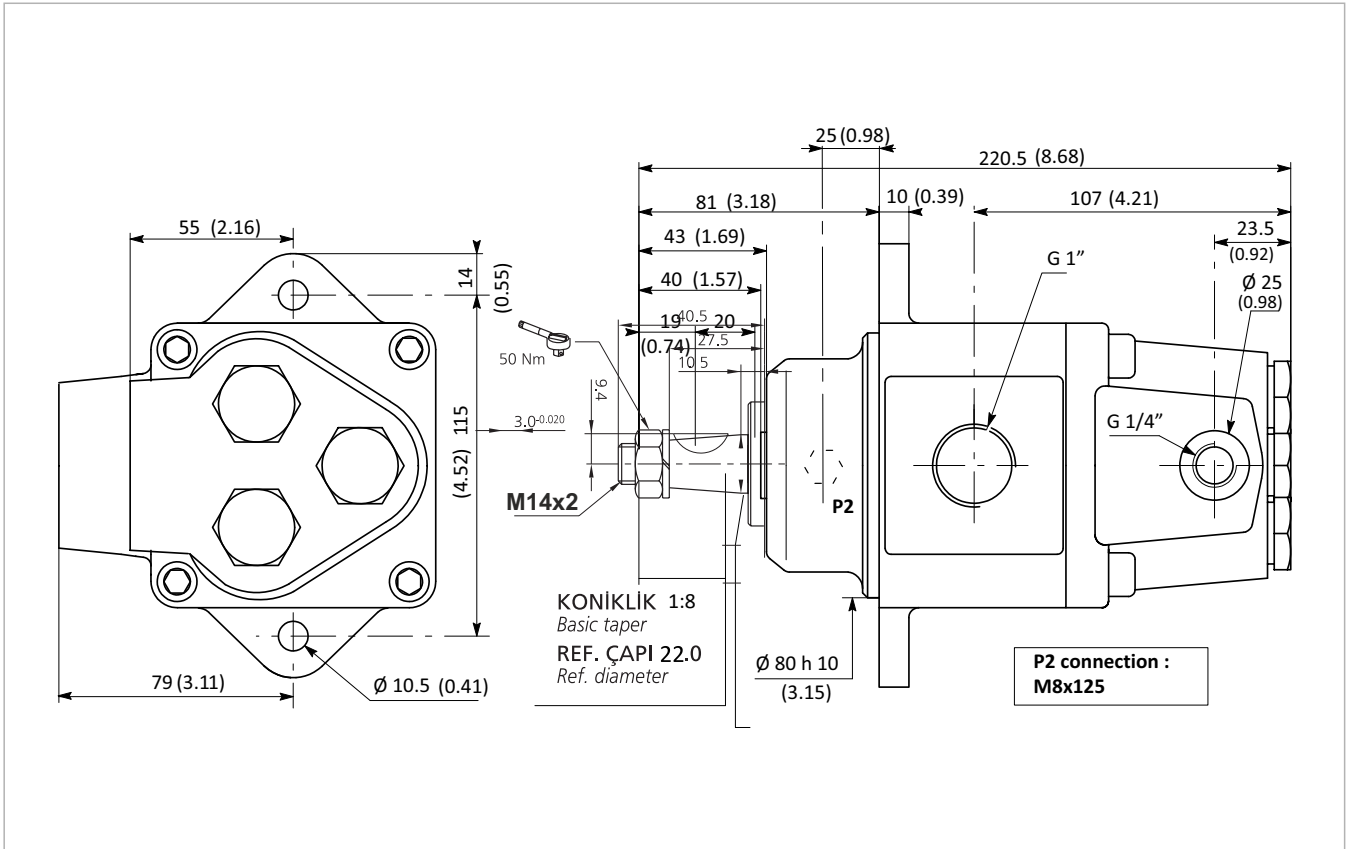

<b>x 1000 rpm</b>	10,50 cc
<b>x 1500 rpm</b>	15,75 cc
<b>Max. Continuous Pump Speed</b>	2800 rpm
<b>Max. Limited Pump Speed</b>	3000 rpm
<b>Max. Continuous Pressure</b>	400 bar
<b>Max. Intermit. Peak Pressure</b>	450 bar
<b>Weight without inlet fitting</b>	8,00 kg
<b>Weight with inlet fitting</b>	8,15 kg
<b>Fluid</b>	Min.B.Hyd.Oil
<b>Inlet</b>	G1 1/4"
<b>Outlet</b>	G 1/2"



## CW

Rotation :  
Fixed-Clock Wise

# A6HP 22

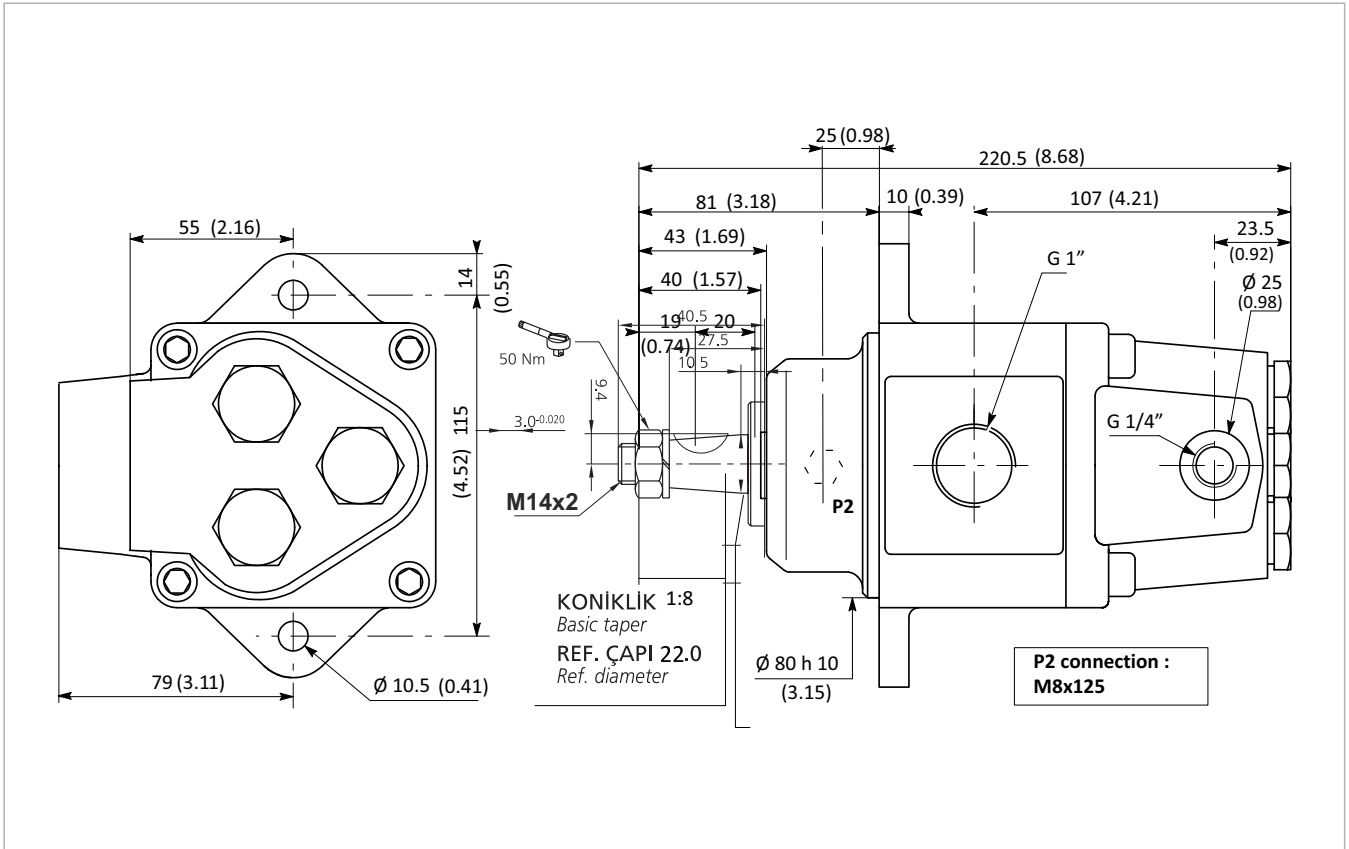

<b>x 1000 rpm</b>	14,73 cc
<b>x 1500 rpm</b>	22,09 cc
<b>Max. Continuous Pump Speed</b>	2800 rpm
<b>Max. Limited Pump Speed</b>	3000 rpm
<b>Max. Continuous Pressure</b>	400 bar
<b>Max. Intermit. Peak Pressure</b>	500 bar
<b>Weight without inlet fitting</b>	8,00 kg
<b>Weight with inlet fitting</b>	8,15 kg
<b>Fluid</b>	Min.B.Hyd.Oil
<b>Inlet</b>	G1 1/4"
<b>Outlet</b>	G 1/2"

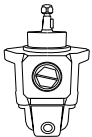

## CW

Rotation :  
Fixed-Clock Wise

# A6HP 35

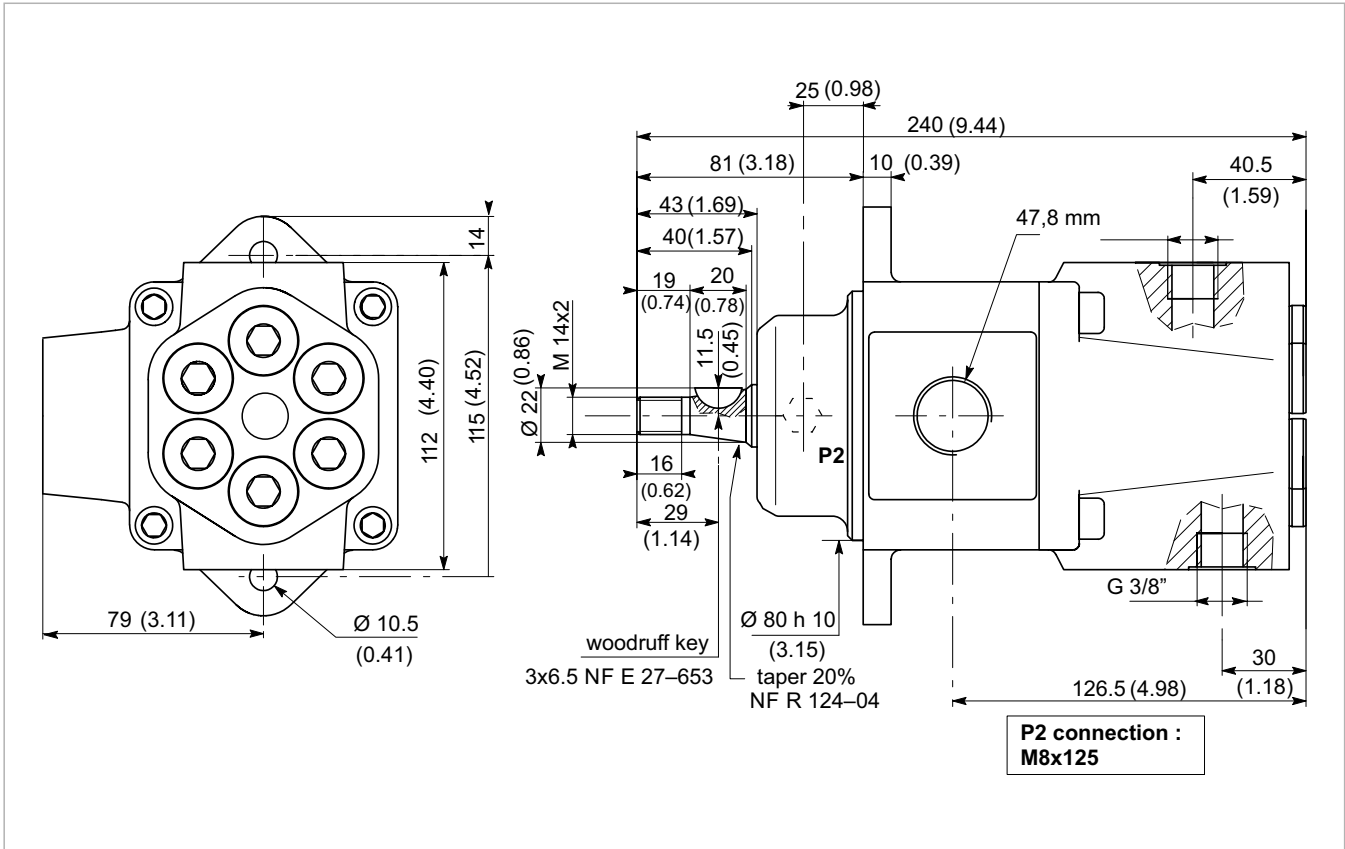

<b>x 1000 rpm</b>	23,70 cc
<b>x 1500 rpm</b>	35,55 cc
<b>Max. Continuous Pump Speed</b>	2500 rpm
<b>Max. Limited Pump Speed</b>	2800 rpm
<b>Max. Continuous Pressure</b>	400 bar
<b>Max. Intermit. Peak Pressure</b>	500 bar
<b>Weight without inlet fitting</b>	12,00 kg
<b>Weight with inlet fitting</b>	12,25 kg
<b>Fluid</b>	Min.B.Hyd.Oil
<b>Inlet</b>	47,8mm
<b>Outlet</b>	26,4mm

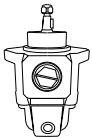

## CW

Rotation :  
Fixed-Clock Wise

# A6HP 45

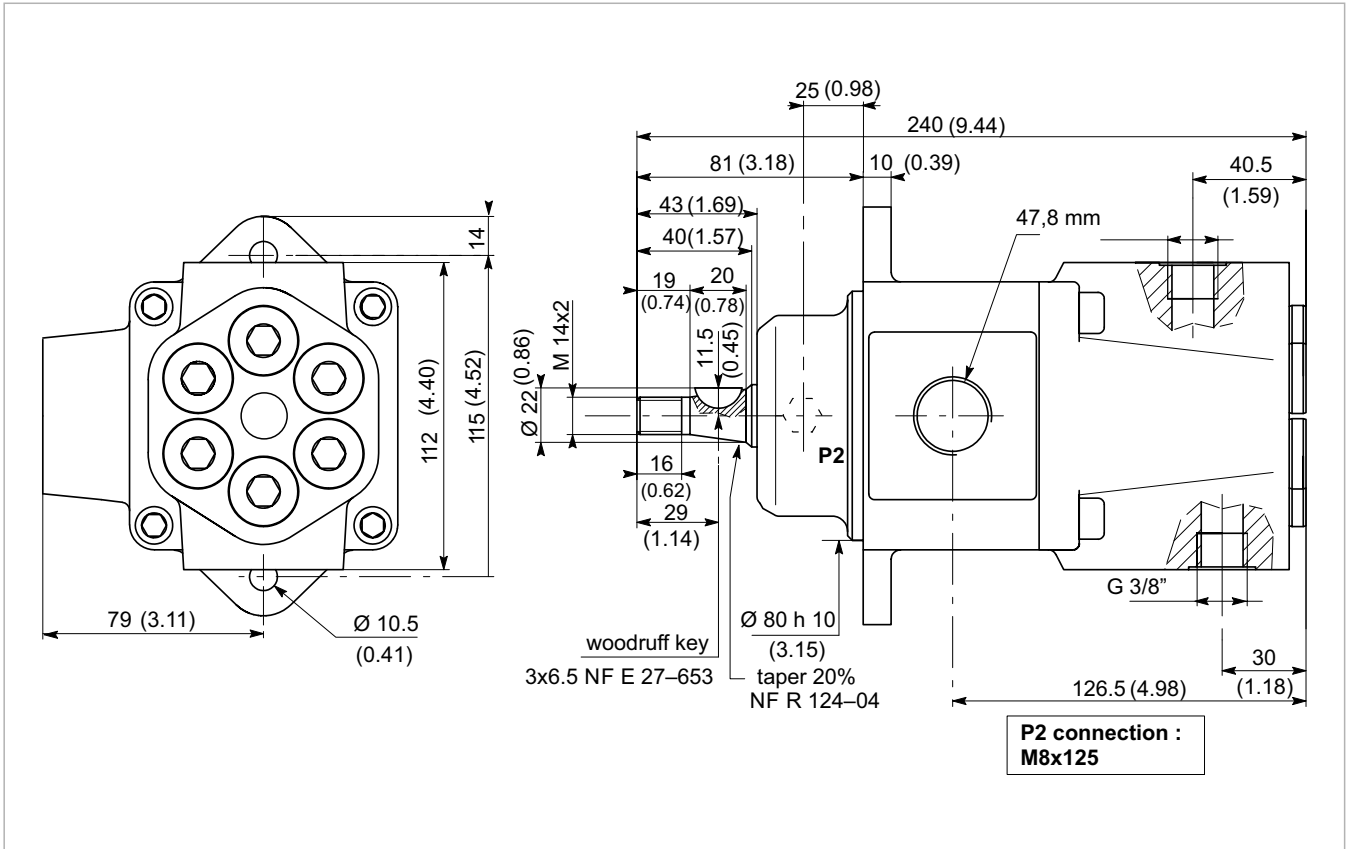

<b>x 1000 rpm</b>	30,40 cc
<b>x 1500 rpm</b>	45,60 cc
<b>Max. Continuous Pump Speed</b>	2400 rpm
<b>Max. Limited Pump Speed</b>	2700 rpm
<b>Max. Continuous Pressure</b>	400 bar
<b>Max. Intermit. Peak Pressure</b>	500 bar
<b>Weight without inlet fitting</b>	12,00 kg
<b>Weight with inlet fitting</b>	12,25 kg
<b>Fluid</b>	Min.B.Hyd.Oil
<b>Inlet</b>	47,8mm
<b>Outlet</b>	26,4mm



## CW

Rotation :  
Fixed-Clock Wise

# Installation & User Guide

High Pressure Piston Pumps designed for Industrial Area.

## INSTALLATION

- Remove the protective covers off the inlet and output ports when connecting tubes or hosing.
- Rinse the tank and the tubes or hoses well to remove any possible contaminants.
- Before connecting up the pump inlet port, fill the tank and allow the oil to flow into a receptacle. This oil can be re-used after proper filtration.

## OIL SUPPLY

Oil and supply line should be clean, and the supply line is airtight.

## SUCTION LINE

Connect the suction line, tighten the suction connection bolts in diametric pairs.  
Connect the pressure line.

## REPAIR

We offers a comprehensive range of services for the repair of our Piston Pumps.  
Repairs to the High Pressure Pump may only be performed by authorized, skilled and instructed personnel.  
Only use original and pre-installed our spare parts from supplied to Manufacturer..

Tested and pre-installed pumps successful repair requiring only little time.

## SPARE PARTS

The spare parts list and the pump order specific.  
When ordering spare parts, quote the material and complete Ordering code number of the Piston Pump as well as the right numbers of the spare parts.

## RISK OF DAMAGE!

Do not touch the drive shaft of the Piston Pump  
Do not touch sensor, valves and fittings  
Do not touch sealing surfaces.

## DIMENSIONS & WEIGHTS

		02	04	06	12	15	22	35	45
- Without inlet fitting	<b>kg</b>	5,50	5,50	5,50	8,00	8,00	8,00	12,00	12,00
- With inlet fitting	<b>kg</b>	5,60	5,60	5,60	8,15	8,15	8,15	12,25	12,25

Address all questions regarding spare parts to your responsible Our Service Partner or the technical service department of the manufacture's plant / factory for the Piston Pumps.

**AVAILABLE VIA E-MAIL ON REQUEST OR EACH PUMP IS  
SUPPLIED VIA STARTING AND INSTALLATION DATASHEETS**

# Complete Product Range

## Piston Pumps

## Piston Motors

# DIN

DIN 5462 / ISO 14  
8x32x35  
8x32x36  
DIN 6885



**A8PD**



**A9MD**

# ISO

ISO 3019-2 (4 BOLTS)  
DIN 5480 -W25,30,35,40,45  
DIN 6885 -Ø20,25,30,35,40,45



**A8PO**



**A9MO**

# SAE

SAE B2 C4 - SAE D  
SAE J498b  
SAE J 744



**A8PS**



**A9MS**

# M2

Fixed Plug-in

DIN 5480 / ISO 3019-2  
W30 - W35 - W40  
M21 - M22 - M23



**A8PL - Dual Flow**



**A9MF - Semi integrated**

# A4

DIN ISO 14  
8x32x36



**A4PP Single Flow**



**A4PL Dual Flow**

# A6

P2 Connection M8x125  
Woodruff key 3x6,5 NF E  
27-653 NF R 124-04  
(2 BOLTS)



**A6HP - High Pressure**



**A7GP - Gear Pump  
A7GM - Gear Motor**

# Contact



Gold Hydraulics, Ltd.

2019® Catalogue

All pictures and banners are patented by owner.

[www.goldhydraulics.com](http://www.goldhydraulics.com)

For more details and other catalogs,  
please send email to our team.

Hydraulic Bent Axis Piston Pumps  
Bent Axis Motors  
Dual Flow Piston Pumps and Gear Pumps...

Sales Team

[info@goldhydraulics.com](mailto:info@goldhydraulics.com)

Order

[order@goldhydraulics.com](mailto:order@goldhydraulics.com)

Management

[mail@goldhydraulics.com](mailto:mail@goldhydraulics.com)



[www.goldhydraulics.com](http://www.goldhydraulics.com)